

MRC Prodigy Advance²

User's Manual



Model Rectifier Corporation
360 Main Street, Suite 2
Matawan, NJ 07747
www.modelrectifier.com
Printed in USA

GETTING STARTED	3
Introduction.....	3
DCC Basic Background.....	3
Specifications and Features	4
System Menu Summary Chart	4
OPERATION	5
Quick Start.....	5
Connecting to Your Layout	5
Running a Loco	5
Controlling Accessory Functions	6
Recalling Locos	6
Deleting Locos	6
Emergency Stopping	6
Speed Steps	6
Yard Mode On/Off	6
Fast Clock	7
Overload and Short Circuit	7
Shutting Down the Prodigy Advance2	7
Cab Setup.....	7
Setting Cab Addresses	7
Setting the Total Number of Operational Cabs (Master Cab Only)	7
Adding More Cabs	8
Setting Last Cab Allowed to Program Locos on the Main Track (Master Cab Only)	8
Setting Last Cab Allowed to Program on the Program Track (Master Cab Only)	8
Programming Decoders.....	8
Decoder Terminology	9
Programming Loco on the Program Track.....	9
Programming Locos on the Main Track.....	10
Reading Loco's Decoder Values on the Program Track.....	10
Configuration Variables.....	11
Most Commonly Used CVs	11
A Word About CV #29	12
Consisting.....	12
Advanced Consisting	12
Programming Advanced Consists	12
Running Advanced Consists	13
Clearing Advanced Consists	13
Universal (Old-Style) Consisting	13
Programming Universal (Old-Style) Consists	13
Running Universal (Old-Style) Consists	14
Clearing Universal (Old-Style) Consists	14
Fast Clock.....	14
Setting Fast Clock (Master Cab only)	14
Setting Time (Master Cab only)	14
Setting Time Rate (ratio) (Master Cab only)	15
Setting AM/PM or Military (24hr) Time (Master Cab only):	15
Reverse Loop	15
Accessory Decoders.....	15
Programming Accessory Decoders with CV# 513	16
Selecting Accessory Decoders	16
Accessory Routes.....	16
Setting Accessory Decoder Routes (Master Cab only)	16
Running Accessory Routes	16
Clearing Accessory Routes (Master Cab only)	16
Expanding Your Layout.....	16
General Troubleshooting	17
Checklist for General Problems	18
Special Troubleshooting	18
SERVICE & SUPPORT	19

GETTING STARTED

INTRODUCTION

Thank you for purchasing MRC's Prodigy Advance² DCC (Digital Command Control) System. You now own one of the most advanced, easy to use DCC systems available. It comes as a complete system with a Command Station (base unit), power supply and LCD Cab/Handheld with cable. The MRC Prodigy Advance² DCC system will enhance the enjoyment of your train layout for many years to come. Here at MRC, we pride ourselves in giving you the most advanced, reliable and easy to use DCC train controls. With up to 9,999 addresses available and use of up to 99 Cabs, you can expand your railroad empire as much as you desire. From a beginner's 4x8 layout to a massive club layout, the Prodigy Advance² gives you everything you want.

NOTE: *Although there are Quick-start instructions on the back of the Cab/Handheld, please read these instructions thoroughly to better understand and enjoy your Prodigy Advance² DCC system.*

DCC BASIC BACKGROUND

A DCC system consists of a DCC Command Station that sends DCC commands to your layout and DCC decoders installed in your locos that receive the DCC commands. Each decoder equipped loco has its own address. Each decoder receives DCC commands but only follows those commands matching its address. No more multiple blocks and no more multiple power packs. With DCC, you can run different locos with different speeds and directions all on the same track. You can also turn on/off the locomotive's headlight and activate sounds if your loco is equipped with a sound decoder. Please visit our website at www.modelrectifier.com for more information about other DCC products.

Please read this manual and your decoder manual carefully before installing and operating your DCC system.

NOTE: *The Prodigy Advance² does not support NON-decoder equipped or analog locos.*

NOTE: For more information on DCC or Prodigy Advance², visit the Customer Service & Resources section of our web site at www.modelrectifier.com or visit the National Model Railroad Association's website at www.nmra.org.

Specifications and Features

Input: 15-16 volts regulated DC, 3.5 Amps universal switching power supply (good for both USA and Europe)

Output: DCC signal with 14.5 V amplitude, for HO and N scales
Scales larger than HO may need an MRC Power Booster

Maximum Current: 3.5 Amps

Maximum number of Cabs: Use up to 99 Cabs

Address Capability: 2-digit (1-127) or 4-digit (128-9,999)

Speed Steps: 14/28/128

Accessory Functions: 28 (F0-F28)

Advanced and Universal Consisting

Program Loco on Program Track

Program Loco on Main Track

Read Loco on Program Track

System Menu Summary Chart

Most functions are initiated by pressing their associated keys. However, there are ten functions initiated by pressing the **SYS** key followed by a numeric key (**0-9**). The following table summarizes these ten functions and the information about each function is found in the manual.

KEYS	FUNCTIONS
SYS + 0	Clear routes
SYS + 1	Set time - Fast Clock
SYS + 2	Set time ratio - Fast Clock
SYS + 3	Yard mode on/off (see page 6)
SYS + 4	Set time mode: AM/PM/military - Fast Clock
SYS + 5	Set routes
SYS + 6	View your Cab address and set Cab address
SYS + 7	Set last Cab allowed to program locos on the Main Track
SYS + 8	Set last Cab allowed to program locos on the Program Track
SYS + 9	Set total number of operational Cabs

Press SYS twice to display the software version for your Prodigy

OPERATION

QUICK START

Connecting to Your Layout

Follow the diagram to connect the Command Station (base unit) to your layout.

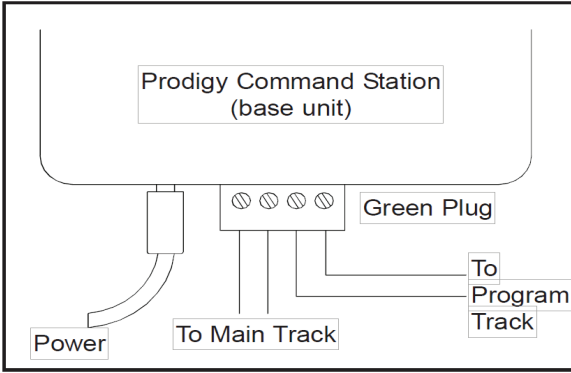

1. Plug the power supply into the base unit.
2. Plug the AC line cord (110VAC, 60Hz) into a wall outlet.
3. Using a small flat-bladed screwdriver, attach two wires (22 AWG or heavier) from the Main Track layout to the terminals marked Main Track and two wires from the Program Track to the terminals marked Program Track
4. Plug one end of the cable into the Cab/Handheld and

- DO NOT connect the programming track and the main track. This will damage the unit.** the other into a Cab Jack on the base unit. Do not use the jack labeled "Factory Use Only" as this is for future upgrades.
5. Double-check all wiring and then turn the power switch on the base unit to the "On" position. The pilot light should be on and you will be ready to run your **decoder equipped** locos.

If you have more than one cab, you will need an Extension Plate (Item: 0001501) for your extra cab. See **Adding More Cabs** (page 8).

Running a Loco

NOTE: First, turn the Cab switch on the base unit to "Cab #1 to #8" for faster response time.

To run a loco, you have to first know its address. Most decoders you purchase have the factory default address #3. If you purchase a decoder equipped loco, its address may be its road number. Read your decoder and/or loco manual for your decoder address.

To select a loco, press the **LOCO** key on your cab. Using the numeric keypad (**0 - 9**), enter the loco address. Press **ENTER**. You have just acquired the loco. The Cab will automatically remember the loco address for later recall.

Use the **DIRECTION** key to set the loco's direction. Use the **THROTTLE** knob to set the loco's speed. The selected loco, or current loco, will begin moving. For increasing or decreasing the loco's speed by 1, please tap the **+1** or **-1** key. **Do not** hold the **-1** key, since this is also the **DEL** key and will delete the loco. To toggle the headlight (F0) on or off, press **0**.

NOTE: A blinking loco address indicates that another Cab is also controlling that loco. This is just a reminder and does not affect your control of the loco. However, since two Cabs are trying to control the same loco simultaneously, the loco may not act as you expect. One operator will have to relinquish control of the loco by deleting the loco from his Cab for proper operation.

Controlling Accessory Functions

To control accessory functions F0 - F9, press **0 - 9**. To control F10 - F28, press **SHIFT** first and then press two digits. When F1-F12 are on, F1 - F12 will be displayed on the LCD. F13 - F28 will not be displayed. (F0 controls headlights and will display with a light bulb icon.)

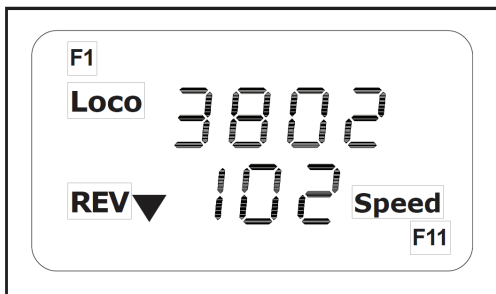

The left LCD display shows that the current loco is 3802 running in reverse at a speed of 102. Its accessory functions F1 and F11 are on.

Recalling Locos

To call up previous locos stored in the memory, press **RECALL**. You can recall up to 25 locos.

NOTE: *Although the Cab can store up to 25 locos during operation, if you unplug*

the Cab from the base unit it will delete all but the last 5 locos used.

Deleting Locos

The Cab can store up to 25 locos. If you select a new loco when the Cab is full, the new loco will replace the current loco. The current loco will be lost. To prevent this, we recommend you recall unused locos and delete them by pressing and holding **DEL** for 2 seconds.

NOTE: *You can't delete all loco addresses. The last address always stays in the stack.*

Emergency Stopping

For emergency stopping of the current loco, press **STOP**. Pressing and holding **STOP** for 2 seconds will stop the Main Track output. The 2 lights on the base unit will blink. To restore the Main Track output, press and hold **STOP** for 2 seconds again.

Speed Steps

Speed steps are incremental steps the loco takes to go from 0 to top speed. There are three speed steps: 14, 28 and 128. The higher the speed steps setting, the higher the number of different speeds on which the loco can operate. When you enter a new loco address (an address that has not been stored in the Cab's memory), Prodigy Advance² will set 28 speed steps as the default setting for that address. In order to operate your loco properly, you may need to change the speed steps setting to match the decoder's speed steps.

To select the speed step setting to better match your decoder's speed step, press **SPD STEP** repeatedly until you see your desired speed step setting. Then press **ENTER**. The selected speed steps setting will apply only to that address.

NOTE: *Use of the speed step button will not alter the speed step originally programmed into the decoder. It only matches the throttle to the decoder. Check your decoder manual for speed step settings.*

Yard Mode On/Off

To toggle the Yard Mode feature on or off, press **SYS** and **3**. In standard throttle mode, the throttle only controls loco speed. When the Yard Mode feature is on ("Yard" displays on the LCD), the yard throttle will control both the speed and direction of the loco.

When the loco is traveling forward, turning the yard throttle clockwise will increase the

loco's speed. Turning counter-clockwise will decrease its speed until 0. Continuing to turn counter-clockwise will reverse the loco's direction. Continuing to turn counter-clockwise will increase the loco's speed in the reverse. Turning clockwise will decrease its speed in the reverse until 0. Continuing to turn clockwise will change the loco's direction from reverse to forward.

Fast Clock

To view the fast clock, press **TIME**. The time will replace the address display on the LCD. You can still run the current loco while the time is displayed. To return to the loco address

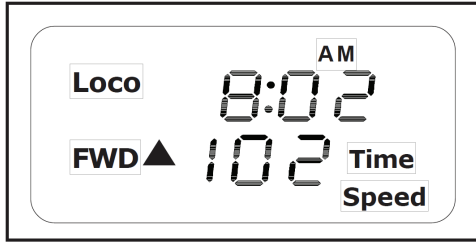

display, press **TIME** again. The time information is stored in the base unit and transmitted to the Cab. Each Cab displays the same time.

The LCD display shows the time as 8:02AM. The current loco is moving forward at a speed of 102.

Overload and Short Circuit

The base unit is rated at 3.5 amps. It is up to you to note how many locos and lighted passenger cars can be run on the layout at the same time without triggering the circuit protector. If there is an overload or short circuit, the base unit will stop Main Track output for 2 seconds then resume. Please remove the overload or short circuit for proper operation. When operating larger layouts with numerous locos and accessories being operated at the same time or when running 2-rail "O" or "G" scales, you may need a DCC power booster. We recommend you use MRC Power Booster (0001521) to boost your DCC layout.

NOTE: Do not use the base unit or power supply to power accessories.

Shutting Down the Prodigy Advance²

Bring all locos to a stop, then turn the power switch to the "Off" position before unplugging the AC adapter from the AC outlet. This will allow the base unit to store the current running information, for the next session.

CAB SETUP

Setting Cab Addresses

You can use up to 99 Cabs with the Prodigy Advance². Each Cab must have a unique address. Any Cab you purchase has the factory default address #1. Cab #1 is the Master Cab that can perform all functions. Any additionally purchased Cabs are also Master Cabs and must have their addresses changed from #1 to their own unique addresses. Keep all cab addresses in numerical order. Never skip a cab address. Doing so can result in a cab not responding properly.

NOTE: Do not duplicate Cab addresses.

To view your Cab address, press **SYS** and **6**. The current Cab address will momentarily display. If you wish to change it, enter a new address (1-99) followed by **ENTER**. Otherwise, press **ENTER** to exit. Do not duplicate Cab addresses.

Setting the Total Number of Operational Cabs (Master Cab Only)

The more Cabs in use at one time, the slower the system response is from cab to loco because the base unit can communicate with only one Cab at a time. Setting the total number of operational Cabs will speed up your Cab's response time.

1. Make sure your Cab is the Master Cab (Cab #1). *Only the Master cab (Cab #1) can set the number of Cabs allowed to operate on the DCC layout.*
2. Turn the Cab Select switch on the base unit to the “All Cabs” position. *The switch must be in this position to limit the number of cabs.*
3. Press **SYS** and **9**.
4. Using **0 – 9**, enter the address of the last operational cab. Press **ENTER**.

EXAMPLE: If you use 10 Cabs and program the Cab addresses #1 - #10, pressing **SYS**, **9**, **10**, and **ENTER** will set the last operational Cab number to 10. The base unit will not spend time trying to communicate to Cabs #11 - #99.

If you use 3 Cabs and program the Cab addresses #1 - #3, pressing **SYS**, **9,3**, and **ENTER** will set the last operation Cab number to 3. The base unit will only communicate to Cabs #1 - #3, thereby improving the response time.

Hint: If you are using 8 Cabs or less, set all Cab addresses sequentially starting from #1 and turn the Cab select switch on the base unit to the “#1 - #8” position. This prevents the base unit from trying to communicate to Cabs #9 - #99, thus saving time.

Adding More Cabs

The base unit of your Prodigy Advance² DCC system has three Cab Jacks. If you use more than three Cabs or you want to install extra Cab Jacks around your layout, you need to use MRC Prodigy Advance² Extension Plates (Item: 0001501). The base unit is able to use five extension plates. If you want to add a sixth extension plate, you need a powered extension plate (Item: 0001502).

Setting Last Cab Allowed to Program Locos on the Main Track (Master Cab Only)

This feature prevents “novice” operators on your railroad from mistakenly reprogramming everything on the layout.

1. Make sure your Cab is the Master Cab. #1.
2. Press **SYS** and **7**.
3. Using **0 - 9**, enter the number of the last Cab allowed to program on the Main Track. Press **ENTER**.

EXAMPLE: If you press the **SYS**, **7**, **3** and **ENTER**. Cab #4 and above cannot program on the Main Track.

Setting Last Cab Allowed to Program on the Program Track (Master Cab Only)

1. Make sure your Cab is the Master Cab.
2. Press **SYS** and **8**.
3. Using **0 - 9**, enter the number of the last Cab allowed to program on the Program Track. Press **ENTER**.

EXAMPLE: If you press **SYS**, **8**, **2**, and **ENTER**, Cab #3 and above cannot program on the Program Track.

PROGRAMMING DECODERS

The Prodigy Advance² allows you to easily program most NMRA compatible decoders. It guides you step by step through the programming process. The Prodigy Advance² allows you to program decoders on a separate Program Track or on the Main Track layout, all without affecting any other locos operating on the Main Track. A Program Track is a separate piece of track isolated from the rest of the layout. It is only used to program decoders.

DO NOT connect the program track and the main track as this will damage the unit.

Decoder Terminology

NOTE: *Before you start programming, please familiarize yourself with the following terminology.*

Loco Address (Adr): The address is the number assigned to a decoder to identify the decoder. The Prodigy Advance² can program two digit (1-127) or four digit (128-9999) addresses.

Start Voltage (SV): This is the voltage required to start the loco's motor and overcome its weight and friction to make it begin to move. You can program your loco with a start voltage so that it will begin to move as soon as the throttle is turned.

Top Voltage (TV): The top voltage (top speed) is the voltage (speed) at full throttle. The Prodigy Advance² top end voltage is set for maximum output.

If you are running a switcher, you may want the top end voltage to be less than full output for more realistic performance at top throttle setting.

Acceleration Rate (Acc): This rate simulates the drag of a heavy load as the loco speeds up so when you increase the speed setting, the loco will gradually increase its speed.

Deceleration Rate (dEc): This rate simulates the drag of a heavy load as the loco slows down so when you decrease the speed setting, the loco will gradually decrease its speed.

PROGRAMMING LOCO ON THE PROGRAM TRACK

1. Make sure your Cab is allowed to program on the Program Track.
2. Place the loco on the Program Track. Press **PROG** to select "Prog Prog Track". Press **ENTER**.
3. First, "Adr" will flash, prompting you to program the loco address. Using **0 - 9**, enter the loco address followed by **ENTER**, or press **ENTER** to skip.

NOTE: *For the beginner or if you want to only program the loco address, you can stop right here. Put the loco back on the Main Track. Select the loco by pressing **LOCO** then enter the loco address and press **ENTER**. Now you can run the loco. **The Program Track is strictly for programming and reading decoders. Locos will not run on the program track.***

4. Next, "SV" will flash, prompting you to program the Start Voltage. Input data and then press **ENTER**.
5. Next, "Acc" will flash, prompting you to program the acceleration rate. Input data and then press **ENTER**.
6. Next, "dEc" will flash, prompting you to program the deceleration rate. Input data and then press **ENTER**.
7. Next, "TV" will flash, prompting you to program the Top Voltage. Input data then press **ENTER**.
8. Finally, "CV#" will flash, prompting you to program a CV (Configuration Variable). At this point, you have already finished most of the decoder programming. You can stop programming here by pressing **ENTER**.
9. If you want to program a CV, enter a CV number. Press **ENTER**. Then enter CV data. Press **ENTER**. "CV#" will flash again, prompting you to program another CV. To skip, press **ENTER**.

NOTE: *Programming a CV with incorrect data can cause a decoder malfunction. Read your decoder manual carefully before programming a CV. Also, read the Configuration Variables section.*

PROGRAMMING LOCOS ON THE MAIN TRACK

Programming on the Main Track can save you the effort of moving a loco to the Program Track for programming. However, you have to know the loco address in order to program on the Main Track. Otherwise you have to program the loco on the Program Track. Not all decoders support the Program on Main feature. Please read your decoder's manual to check whether the decoder supports this feature.

1. Make sure your Cab is allowed to program on the Main Track
2. To program on the Main Track, press **PROG** to select "Prog Main Track". Press **ENTER**. The current loco address will flash, prompting you to program the current loco.
3. To program the current loco, press **ENTER**; to program another loco, enter its address and press **ENTER**.
4. The rest of the programming procedures are the same as the Programming on Program Track procedures (see above). We recommend you bring the loco to a stop before programming because if the moving loco has a bad pickup, it may fail to receive the program command, causing a malfunction.

NOTE: *If you only need to program CV you can short cut by pressing CV ON MAIN*

More about programming locomotive address on the Program Track or Main Track

To program a locomotive address involves programming a series of CVs such as CV1, CV17, CV18, CV19 and CV29. This can be somewhat complicated. For most decoders, Prodigy Advance² automatically handles this for you when programming the loco address. However, it may fail to program some old decoders and some new sound decoders made by QSI®. It does not mean that you cannot program these decoders. It only means you cannot use the Prodigy Advance²'s easy address programming feature. For QSI® decoders please refer to your decoder's manual and use CV programming to program the loco address. For some old decoders, you have to skip the Addr programming and use the CV program mode to program CV29 with a value of 2 and CV1 with a short address (1-127). Detailed steps are as follows:

1. Press Prog to select Prog Prog Track
2. Press Enter six times until CV# displays on the screen
3. To select CV29, press 29 and Enter
4. CV data displays. Press 2 and Enter
5. CV# displays again. Select CV1 by pressing 1 then press Enter
6. CV data displays. Press the loco address (1-127) and then Enter

READING LOCO'S DECODER VALUES ON THE PROGRAM TRACK

The Prodigy Advance² DCC system gives you the ability to read back CV values of a decoder equipped loco on the Program Track. This feature is useful if you do not remember the decoder address or what CV values your decoder has. Not all decoders support this feature. Please read your decoder's manual to check whether it supports this feature. Even with decoders that support the readback CV feature, the unit may fail to read the CV. This does not mean your Prodigy Advance² is defective. No DCC System is able to read all decoders 100%. This should not affect the operation of the decoder because you are always able to program your decoder.

1. Place the loco on the Program Track.
2. Press **PROG** to select “rEAd Prog Track” then press **ENTER**.
3. First, “Adr” will flash, prompting you to read the loco address. Press **ENTER** to read or press **SHIFT** to skip to the next item. It may take several seconds to retrieve the address. If the decoder does not support read back feature, you will receive an “Err” (Error message).
4. Next, “SV” will flash, prompting you to read the Start Voltage. Press **ENTER** to read or **SHIFT** to skip.
5. Next, “Acc” will flash, prompting you to read the acceleration rate. Press **ENTER** to read or **SHIFT** to skip.
6. Next, “dEc” will flash, prompting you to read the deceleration rate. Press **ENTER** to read or **SHIFT** to skip.
7. Next, “TV” will flash, prompting you to read the Top Voltage. Press **ENTER** to read or **SHIFT** to skip.
8. Finally, “CV#” will flash, prompting you to read a CV. To read a CV, enter a CV number and press **ENTER**. After reading a CV, press **ENTER**. “CV#” will flash again, prompting you to read another CV. To end the read process, press **ENTER**.

CONFIGURATION VARIABLES

Configuration Variables, also known as CVs, receive and hold entered data that allow the decoder to be tailored to a specific loco or accessory. Some CVs are also called registers.

The Prodigy Advance² DCC system allows you to perform most basic programming without having to concern yourself with CVs or registers. Of course, if you want to program CVs to custom tailor your decoders or select certain functions, the Prodigy Advance² has this capability.

Most Commonly Used CVs

The CVs listed on the chart below are contained in almost all decoders, with additional CVs for extra functions – sound or light – in more specialized decoders. See the decoder manufacturer’s instruction manual for a list of CVs contained in that specific decoder and what values to enter for those CVs.

CV #	Function
1	Short address
2	Start voltage
3	Acceleration rate (momentum)
4	Deceleration rate (momentum)
5	Top voltage
6	Mid voltage
7	Manufacturer version #
8	Manufacturer ID #
17	Extended address - upper & lower bytes, 4 digit address
18	Extended address - upper & lower bytes, 4 digit address
19	Advance consist
29	Configuration data #1

A Word About CV #29

CV29 is the most important CV of the decoder. Improperly programming the CV29 may cause decoder malfunction. We do not recommend you program CV29 yourself because the unit will take care of it for you in most cases. When you program your decoder's address with Prodigy Advance², it will automatically program CV29. However, for some QSI® sound decoders that talk, you need to program CV29 with value of 2 for a short address (1-127) and program CV29 with value of 34 for a long address (128-9999). If you want to reverse the loco's polarity or set 14 speed steps, you have to reprogram CV29 after programming the loco's address. Please use the following table to reprogram CV29. The value of CV29 depends on the loco's address.

For further information about CV29, visit the Resource section of our website.

CV #29 Table

Analog	Speed steps	Direction	When address is 1-127	When address is 128-9999
disable	28	normal	CV29=2 (default)	CV29=34 (default)
disable	28	reverse	CV29=3	CV29=35
disable	14	normal	CV29=0	CV29=32
disable	14	reverse	CV29=1	CV29=33
enable	28	normal	CV29=6	CV29=38
enable	28	reverse	CV29=7	CV29=39
enable	14	normal	CV29=4	CV29=36
enable	14	reverse	CV29=5	CV29=37

CONSISTING

Sometimes more than one loco is needed to haul heavy loads. These grouped locos are known as a multiple unit or a consist. The Prodigy Advance² DCC system allows you to build consists quickly and easily. There are two types of consisting methods, Advanced Consisting and Universal or Old Style Consisting.

Advanced Consisting

You can only apply Advanced Consisting to a mobile decoder that has CV19 to support this feature. When you program a loco into an Advanced Consist, you actually program the consist number into the decoder's CV19, which will override the decoder's original address. Therefore, the loco will no longer respond to commands addressed to its original address, but rather only to commands addressed to the consist number. All decoders in the consist will receive the command addressed to the consist number at the same time and act as one until you clear the consist. The base unit does **not** hold the consist information. With Advanced Consists, **always** remember to clear the consist when you are finished or the locos will still run as part of the consist next time you use them.

Programming Advanced Consists

1. Press **CONSIST** until "Cons SET" flashes in the LCD display. Then press **ENTER**.
2. "Cons #" will display, prompting you to enter a consist number. Enter a consist number (a short address 1-127) followed by **ENTER**.

NOTE: Write down the consist number. You will need it later to clear the Advanced Consist.

3. “Add Loco” will display, prompting you to add a loco into the consist group. Enter the address of a loco you want to add. Press **DIRECTION** if you want the loco’s direction reversed (forward is the default setting). Then press **ENTER**.
4. “Add Loco” will display again, prompting you to add another loco into the consist group. You can add as many locos into the consist as you would like. To end programming, press **ENTER**.

Running Advanced Consists

Running Advanced Consist is just like running a single loco.

NOTE: *After setting up your consist group, use the consist number to run the consist.*

1. Press the **LOCO** key. Make sure “Loco” appears on the LCD. If not, press the **LOCO** key again. Enter the consist number and press **ENTER**.
2. Turn the throttle and all the locos in the consist will start moving together. To control an individual loco’s accessory functions use either the consist number or the loco’s original address. Read your decoder’s manual to find how to control the accessory functions.

Clearing Advanced Consists

1. Press **CONSIST** until “Cons cLr” flashes in the display. Then press **ENTER**.
2. “Cons#” will display, prompting you to input the consist number. Enter number of the consist you want to clear and press **ENTER**.

Once you clear the consist, each loco will respond immediately to its original speed command.

NOTE: *If you forget the consist number, each loco’s address in the consist must be reprogrammed to its address on the Program Track, or program CV19 to zero.*

Universal (Old-Style) Consisting

This feature allows you to use older decoders that do not have CV19 to support Advanced Consisting. In this type of consisting, the base unit stores all the information of the consisting locos and makes them run as a single loco. When you adjust the speed of the lead loco, the base unit distributes the speed setting to all the original loco addresses in the consist by sending the speed command to each individual loco. Although the consist acts as one loco, there is a slight time lag between the locos you may not be able to detect.

Locos consisted in this fashion will revert to their original addresses and direction settings when removed from the layout. If they are removed from the layout and placed back onto the layout during the same session, they will remain consisted. They will not be “consisted” if removed to another layout.

The Prodigy Advance² DCC system allows only ONE Universal Consist at a time regardless of how many Cabs are in use. *One Universal Consist per system, not per Cab.* Once programmed, the base unit will remember the consist group until you clear it. Turning off the base unit power will not clear it.

Programming Universal (Old-Style) Consists

1. Press **CONSIST** until “oLd SET” flashes in the display. Then press **ENTER**.
2. “LEAd Loc” will flash, prompting you to enter the address of the lead loco. Enter the lead loco’s address. Press **DIRECTION** if you want the loco’s direction reversed (forward is default setting) and press **ENTER**.

3. “Add Loco” will flash, prompting you to add another loco into the consist group. Enter a loco address. Press **DIRECTION** if you want the loco’s direction reversed (forward is default setting) and press **ENTER**.
4. “Add Loco” will flash again, prompting you to add another loco into the consist. You can control up to 4 locos total (including the lead loco) in a Universal Consist. To end programming, press **ENTER**.

Running Universal (Old-Style) Consists

NOTE: *Running a Universal Consist is different from running a single loco. After setting up your consist group, use the lead loco’s address to run the consist.*

1. Press **CONSIST** then **LOCO**. Make sure “Cons” appears on the LCD display.
2. Enter the address of the lead loco and press **ENTER**.
3. Turn the throttle and all the locos in the consist will start moving together.
4. To control accessory functions, use each loco’s original address.

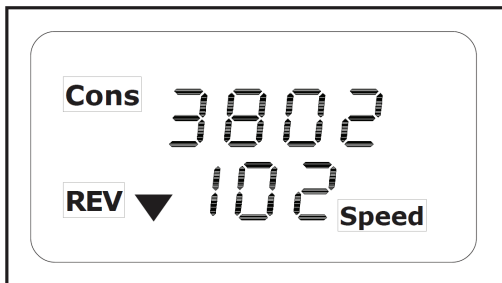

The LCD display shows a Universal Consist group led by lead loco 3802 running in reverse at a speed of 102.

NOTE: *When running a Universal Consist, LCD shows “Cons.” When running an Advance Consist, LCD shows “Loco.”*

Clearing Universal (Old-Style) Consists

To clear a consist, press **CONSIST** until “Cons oLd cLr” flashes in the display. Then press **ENTER**. Next using the **RECALL** button select the Cons address you cleared. Press and hold **DEL** to delete from the recall stack. *Turning off the power on the base unit will not clear the consist.*

Once you clear the consist, each loco will immediately respond to its original speed command.

FAST CLOCK

Setting Fast Clock (Master Cab only)

Only the Master Cab (Cab #1) can program the time, time ratio, and AM/PM or military (24 hr) time. The time settings entered by the Master Cab are stored in the Prodigy Advance² DCC system base unit memory. The settings will remain unchanged until you reprogram them. The time is sent to all Cabs operating on the layout so railroad schedules can be maintained.

NOTE: *Write down the time before shutting down, so you can reset the time for your next operating session.*

Setting Time (Master Cab only)

1. Make sure your Cab is the Master Cab.
2. Press **SYS** and **1**. The current time will be momentarily displayed.
3. Enter the new time. Press **ENTER**.

Setting Time Rate (ratio) (Master Cab only)

The time rate is how many real seconds are in one fast clock minute.

EXAMPLE: Rate 1 means that one real second equals one fast clock minute, or 60 times as fast as real time. Rate 30 means 30 real seconds equal one fast clock minute, or twice as fast as real time. Rate 60 means 60 real seconds equal one fast clock minute, or real time.

1. Make sure your Cab is the Master Cab.
2. Press **SYS** and **2**. The current rate will be displayed for a second.
3. Enter the new ratio. Press **ENTER**.

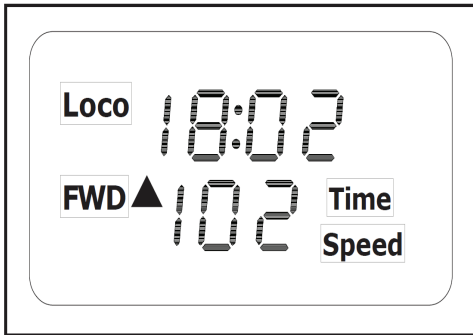

Setting AM/PM or Military (24hr) Time (Master Cab only):

1. Make sure your Cab is the Master Cab.
2. Press **SYS** and **4**. Either "AM", "PM" or nothing (military) will display on the LCD.
3. Repeat step 2 above to select the desired setting.

REVERSE LOOP

The following diagram shows a reverse loop with a double-pole double-throw (DPDT)

switch. It allows you to change the polarity of the reverse loop section. Before a loco crosses the first insulated gap you must make sure the polarity of reverse loop section and Main Track are matched at the first gap. If not flip the switch. Otherwise it will cause a short circuit. After the loco passes the first gap completely, you need to change the polarity of the reverse loop section by flipping the switch so that the polarity of the reverse loop section and Main Track are matched at the second gap. The MRC Auto Reverse Loop Module (#AD520) can be used in place of the DPDT switch for automatic operation of the loop. See your hobby dealer to purchase this item.

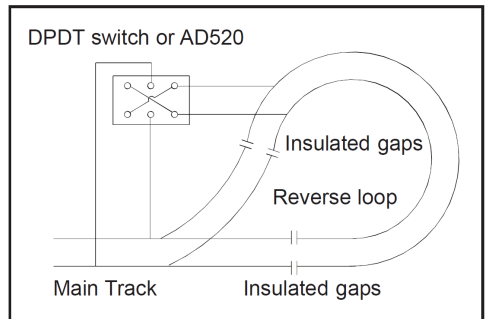

ACCESSORY DECODERS

The Prodigy Advance² will handle most NMRA compatible accessory decoders. This type of decoder can operate turnouts (switch tracks) or toggle accessories, like building lights, on and off from your Cab. The accessory decoder outputs can be programmed for a variety of options so you can use them for twin-coil switch machines (momentary on), slow-motion switch machines (constant on or latching), or signal lighting (various flash rates). Refer to your accessory decoder's instruction manual for programming procedures and CV values.

Most accessory decoders have their own unique address (CV #513) and some have multiple outputs (groups of 4). Accessory decoder's and loco decoder's addresses are different, so they can be operated independently of each other (even if the address values are the same).

Programming Accessory Decoders with CV# 513

1. Press **PROG** until you reach “Prog Prog Track”.
2. Press **ENTER** until “CV #” displays.
3. Enter 513. Press **ENTER**.
4. Enter the accessory decoder address. Press **ENTER**.
Read your accessory decoder manual for proper addressing.

Selecting Accessory Decoders

1. Press **ACCY**. Using **0 - 9**, enter the accessory decoder address. Press **ENTER**.
2. “1or2” will display reminding you to press only 1 or 2 to control the accessory. Press **1** to turn the accessory on and **2** to turn it off. You can keep pressing **1** or **2** until you are done with accessory.
3. Press **ENTER** to escape accessory operation.

ACCESSORY ROUTES

Grouping of turnouts (or accessories) can be consisted to form a route. The Prodigy Advance² DCC system allows up to 31 routes and up to 8 accessories in each route. Please do not set a route number higher than 31, nor add more than 8 accessories into one route.

Setting Accessory Decoder Routes (Master Cab only)

1. Press **SYS** and **5**.
2. “Route SET” appears in display. Press **ENTER**.
3. Enter route number (1 – 31). Press **ENTER**.
4. “Add Accy #” will display. Using **0 - 9**, enter an accessory address (1 to 255). If you want this accessory (turnout points) to move in a direction opposite its normally programmed direction (reverse polarity), use **DIRECTION** to set its direction. Press **ENTER**.
5. “Add Accy #” will display again, prompting you to add another accessory into the route. Repeat above steps to enter up to 8 accessories into one route.
6. When finished setting up your route, press **ENTER**.

Running Accessory Routes

1. Press **ROUTE**. Enter the Route number you wish to run. Press **ENTER**.
2. “1or2” will display reminding you to press only **1** or **2** to select the route.

Clearing Accessory Routes (Master Cab only)

1. Press **SYS** and **0**. Then press **ENTER**.
2. Enter the route number. Then press **ENTER**.

EXPANDING YOUR LAYOUT

The following diagram illustrates how to expand your layout with power boosters.

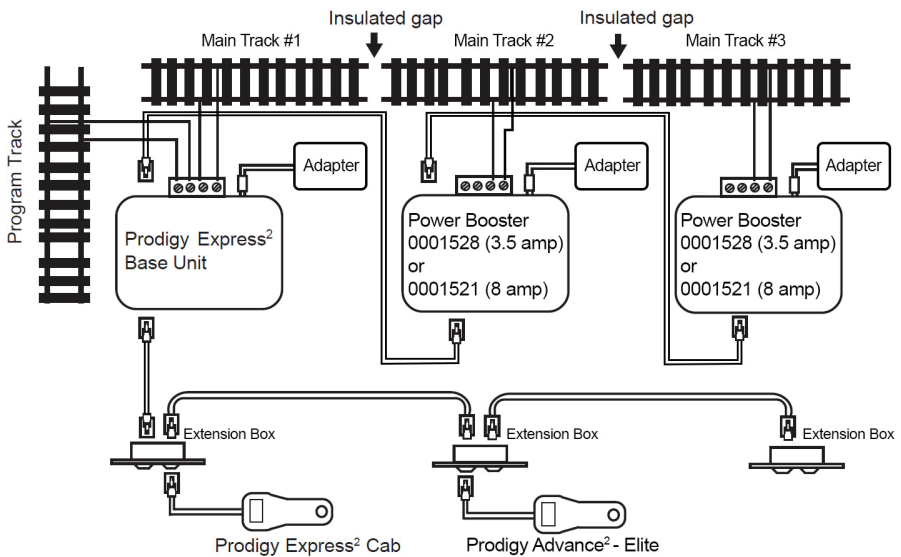

TROUBLESHOOTING

GENERAL TROUBLESHOOTING

It takes the Command Station, the decoders and your layout to make the DCC system work. This Trouble Shooting Section has been arranged in a manner easiest for you to find the cause of your problem. Please go through this section in the **exact** order it appears because each following set of instructions assumes that the preceding set has been tested and that component of the DCC system found not defective.

1. **Turn on the power of the base unit. The pilot light should turn on.** If not, make sure the power supply is securely plugged into the base unit and into a working AC wall outlet. Then turn off the power, wait 3 seconds and turn on the power again. If pilot light still does not turn on, send the unit in for repair.
2. **If the link light and pilot light are alternately flashing, you may have a short.** Pull the green plug from the back of the unit. If the pilot light comes back on, you have a short in your layout. If the alternating link light and pilot light flashing continues send the unit in for repair.
3. **Check the Main Track output.** Place an analog loco or test light on the Main Track. The loco should buzz or the test light should light. If not, check all connections and make sure the rear green plug is securely plugged in. Make sure the screws on the green plug are tightened on the wire and not on the wire cover (insulator). If the analog loco still does not buzz or the test light does not light, send the unit in for repair.
4. **Check the LCD display.** The Cab LCD should display the current loco when the power is on. If not, check the cable connection and make sure all cable jacks are fully plugged in. If the LCD still does not display anything, send the unit in for repair.
5. **Check the communication between the base unit and the Cab.** Press **2**. F2 should momentarily display on the LCD and the Link light should blink. If not, set the Cab to be the Master Cab (Cab# 1) by pressing **SYS, 6, 1** and **ENTER**. Make sure there is no other Master cab in the system and try again. If there is still no communication, send the unit in for repair. If there is communication, you may have the wrong Cab setup. Read the Cab Set up section (See page 7).

6. **Your loco may have a pickup problem.** You should periodically clean your track and your loco's wheels. Oxide coating or dirt on either the track or loco's wheels often causes intermittent and jerky operation.
If you pass the above steps, your Command Station and Cabs are fine. The problem may lie in the decoder.
7. **Your decoder may have lost its memory or is in Advanced Consist mode (CV19 is not 0).** Reprogram the loco address and try again. If the loco still does not respond, you will need to perform a factory reset. Consult your loco manual for the correct CV setting to perform the reset.
8. **Your decoder may have too much momentum.** Program the loco with zero acceleration and deceleration rates.
9. **Clear the Advanced Consist or Universal (Old-Style) Consist.** Clearing Advance Consist (See Page 13). Clearing Universal (Old-Style) Consists (See page 14).
10. **The current loco speed command may not match the decoder's speed steps.** Change speed steps to match your decoders speed steps (See page 6).
11. **Check the decoder wiring and make sure it's correct.**
12. **Remove the decoder and test it on a decoder tester** to make sure the decoder is working. If the decoder is working, **check the loco** to make sure the loco is working before installing the decoder.

CHECKLIST FOR GENERAL PROBLEMS

1. Clean your track, layout and the loco's wheels.
2. Check the layout's wiring.
3. Reprogram loco address and other data.
4. Reset Cab by unplugging the Cab.
5. Reset the base unit by turning the power off.
6. Check loco for proper decoder installation.
7. Check wiring from Cabs to the base unit and from the base unit to your layout.
8. Check for short circuits and/or stray objects lying across track rails.
9. Make sure the Link light flashes when you press F2.
10. Make sure you are not plugged in to the booster bus.

SPECIAL TROUBLESHOOTING

Base unit pilot light is on but Cab does not display anything on the LCD display

1. Check that the Cab cable is securely plugged into the base unit.
2. Replace the Cab cable with a known working cable.
3. Try Cab/cable combination in another base unit Cab Jack.
4. If using remote plug ports around your layout, check wiring/cables from the base unit to a remote plug port or try moving the Cab/cable combination to a different Cab Jack.

The loco's headlight turns itself off

When you press 0 to turn on the loco's headlight, the base unit will send the command to the decoder to turn on the loco's headlight. The base unit will not continuously send the accessory command to the decoder like the speed command. When the loco hits a dirty track and loses its power, it will reset and lose the accessory command. It will continue

running but may be jerky because the base unit continuously sends speed commands. You should clean the track and the loco's wheels to improve the loco's pickup.

During operation all locos stop responding

Turn base unit power switch off, wait 3 seconds and turn the power back on.

Your loco doesn't work while other locos work

The decoder may have lost its memory. Reprogram loco address. If the loco still does not respond, you will need to perform a factory reset. Consult your loco manual for the correct CV setting to perform the reset.

Your Cab doesn't work while other Cabs work

Unplug the Cab, wait 3 seconds and plug the Cab in again. If the Cab does not display anything, please check the cable connection as mentioned above. Make sure each Cab address is unique.

Make sure your Cab address is an operational address (1-99) and that all of your Cab addresses are in sequential order. Never skip an address when operating multiple Cabs. If the Cab still does not work, it may need repair.

Your Cab operates locos but cannot program on the Program Track

1. If the Link light does not flash when you enter a data and press **ENTER**, it may have been limited by the Master Cab and is not allowed to program on the Program Track.
2. If the Link light flashes when you enter a data and press **ENTER**, then test the Program Track output. To test, place an analog loco on the Program Track. During the programming process, the Link light should be on and the analog loco should buzz. If the Link light is on and the analog loco does not buzz, it is a defective Program Track output.

Your Cab operates locos but cannot program on the Main Track

It may have been limited by the Master Cab.

Your Cab operates locos but cannot program an Advanced Consist

It may have been limited by the Master Cab. Your Cab must be able to program on the Main Track to set an Advanced Consist.

SERVICE & SUPPORT

Your Prodigy Advance² DCC has been thoroughly tested at the factory.

Do not shut down your layout unnecessarily. Before returning your unit for repair or servicing, **please read both General Trouble Shooting and Special Trouble Shooting section.**

1. If it should become necessary to return the Prodigy Advance² for repair/replacement, be sure to contact MRC technical support **beforehand** to ensure you receive the correct fees for service. This also gives us the opportunity to troubleshoot issues which may be solved with technical phone support.
2. In order to receive warranty service, we require a copy of the original sales receipt to validate the warranty period. Include a note briefly describing the issues along with your name, address, phone number, and email address.
3. Questions regarding the three-year limited warranty* policy or troubleshooting issues can be directed to MRC Customer Support by calling 1-732-225-6360 from

Monday to Friday, between 8:00 AM and 5:00 PM EST, or by emailing mrccsupport@modelrectifier.com

4. The three-year limited warranty* does not include return shipping for customers outside of the continental United States (including Hawaii, Alaska, Canada, and Mexico). Customers outside of the continental United States must contact us for return shipping rates.

***THREE YEAR LIMITED WARRANTY**

Model Rectifier Corporation (MRC) will, subject to the conditions explained and set forth below, repair at its expense, within three calendar years from the date of sale, any component of this MRC product which is proven defective by reason of improper workmanship or materials. MRC will repair said component(s) without charge for necessary parts or labor. If the unit cannot be repaired, it will be replaced with another unit or similar product of equal or greater value.

CONDITIONS

1. Limitation to original purchaser and proof of date of purchase: The obligations of MRC set forth herein shall only extend to the original purchaser. The burden of proof as to the date of purchase is on the purchaser. It is recommended that you retain your bill of sale or sales receipt and include it with the return of your product, keeping a copy of it for your records. This bill of sale or sales receipt must have the date of purchase and the name and address of the dealer.
2. Validation of the Warranty: The validity of the above state warranty is contingent upon purchaser possessing an original copy of the sales receipt that shows the product's name and/or model number, purchase date, name of the dealer, and the address of the dealer. The burden of proof rests with the purchaser of the product.
3. Exclusions from Warranty: The warranty does not apply to (a) any marring, scratching, or defects in decoration and/or finish, (b) any damage resulting from misuse, abnormal service, water, or weather damage, (c) any damage incurred in shipping and handling, (d) and incidental or consequential damage(s) caused by or resulting from a defect in material or workmanship or other equipment failure, (e) any damage arising from the product not being used in accordance with the instructions provided. Your sole remedy shall be repair or replacement as herein above expressed. Under no circumstances shall MRC be liable for any losses or damage, direct or consequential, arising out of the use of or inability to use this MRC product. No implied warranty shall continue beyond the three years from the date of purchase. Further, any modification, alteration, or tampering with the MRC product or any repair other than that done at the factory automatically voids the warranty.
4. Notice: Some states do not allow limitations on how long an implied warranty lasts or the inclusion of limitation of incidental or consequential damages, so the above state limitations or exclusions may not apply to you. This warranty gives you specific legal rights and you may have other rights which vary from state to state.
5. Customers outside the continental United States, including Hawaii, Alaska, Canada, and Mexico, must contact MRC for return shipping rates for both warranty and non-warranty repairs. Email us at mrccsupport@modelrectifier.com

Model Rectifier Corporation
360 Main St. STE # 2
Matawan, NJ 07747 USA
Telephone 1-732-225-6360
www.modelrectifier.com